

HRD LOCKOUT ASSEMBLY

DESCRIPTION

Fike's High Rate Discharge (HRD) Mechanical Lockout Assembly provides a means for the user to physically prevent an accidental discharge of the HRD suppression container into the process vessel and to electrically prevent the unintentional arming of the suppression system by the Fike Explosion Protection Controller (EPC).

The HRD Mechanical Lockout consists of a 2-position lockout blade assembled between flanges. The assembly is equipped with a primary sensor and magnet, and also includes a locking pin to secure the lockout blade in each position (open/closed). The HRD Lockout Assembly can be secured with a padlock or tag, in compliance with regulatory standards.

The HRD Lockout Assembly can be installed in hazardous area locations with use of the optional intrinsic safety barrier. The HRD Lockout Assembly also features a mounting location for an optional secondary sensor to indicate when the lockout is completely closed and in the safe position.

FEATURES

- 300 series stainless steel construction
- Simplified design and electronics
- Optional secondary sensor for safe condition monitoring
- Increased safety for personnel in compliance with:
 - OSHA requirement 29 CFR 1910.147, The Control of Hazardous Energy (Lockout/Tagout)
 - NFPA 69-2008, 11.3 Personnel Safety
 - EN 14373, 8 Instructions for installation, commissioning and maintenance
- Compatible with existing installations
- No impact on suppression efficiency



SPECIFICATIONS

HRD Lockout Rating and Specifications	
Part Numbers	E70-063 (4 IN), E70-064 (6 IN)
Sizes	4 IN (used with the 2.5L, 5L, 10L, 20L and 30L HRD containers) 6 IN (used with the 50L HRD Ver 1 and Ver 2 containers)
Weight	15 lb / 6.8 kg (4 IN), 34 lb / 15 kg (6 IN)
Materials	300 Series Stainless Steel Construction
Primary and Secondary Sensor Rating and Specifications	
Part Number	02-13579-1
Thread Size	M8 x 1.25
Material	Stainless Steel barrel and retaining nuts
Power	5 W Max
Voltage	175 Vdc Max
Current	0.25 A Max
Operating Temp	-40 to 221°F (-40 to 105°C)
Cable	39 IN (1m) x 24 AWG, stripped and tinned ends

ACCESSORIES

Intrinsic Safety Barrier Rating and Specifications (Required for Hazardous Locations)	
Part Number	02-13775
Operational Voltage	20 to 250 VAC / 20 to 125 VDC
Frequency	≥ 40 to ≤ 70 Hz
Power Consumption	≤ 3 W
Cable Resistance	≤ 50 Ω
Degree of Protection	IP20
Ambient Temperature	-13 to 158°F (-25 to +70°C)

An Intrinsic Safety Barrier is required when installing the primary sensor in a hazardous area location.

Intrinsic Safety Barrier	
Part Number	02-13775

An optional secondary sensor is available to indicate when the lockout is completely closed and in the safe position.

Sensor	
Part Number	02-13579-1

A Retrofit Shim is required for 4" HRD Containers manufactured prior to January 2010 to prevent the gate from binding. The Retrofit Shim is installed between the HRD Container and the HRD lockout. Refer to the HRD Container manual E06-082-3 for additional information.

4" HRD Retrofit Shim	
Part Number	E70-0230

APPROVALS:

- ATEX Ex II (1) GD [EEx ia] IIC/IIB, Ex II 3 G Ex nA nC [nL] IIC/IIB T4
- FM -
 - Class I, Div. 1&2, Grp A,B, C, D;
 - Class 1, Zone 0,1 or 2 Grp IIC, IIB, IIA
 - Class II, Div 1&2, Grp E, F, G;
 - Class III, Div 1
- CSA

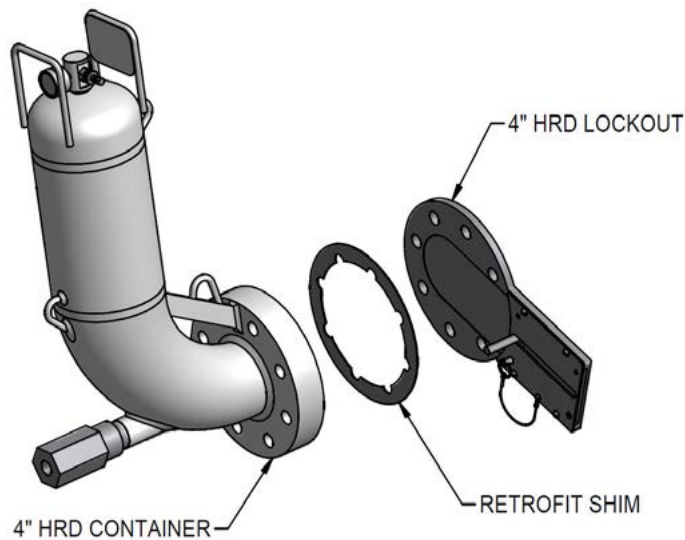

(Retrofit Shim is required for 4" HRD Containers manufactured prior to January 2010)